

VARIES, SEE NOTE 7

REMOVABLE BOLLARD PLAN

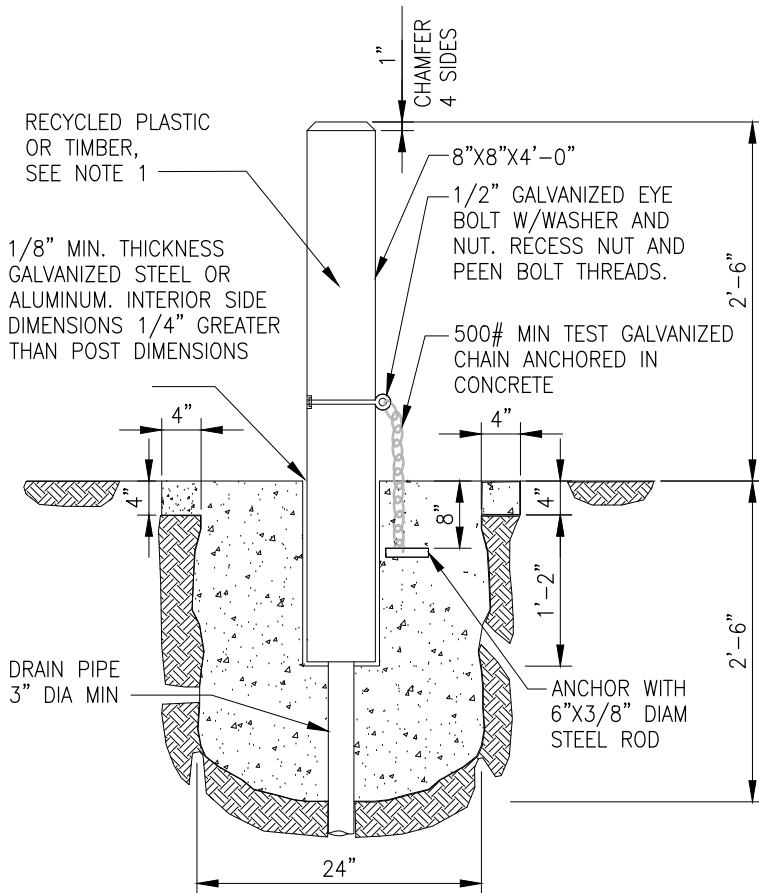

REMOVABLE BOLLARD SECTION A

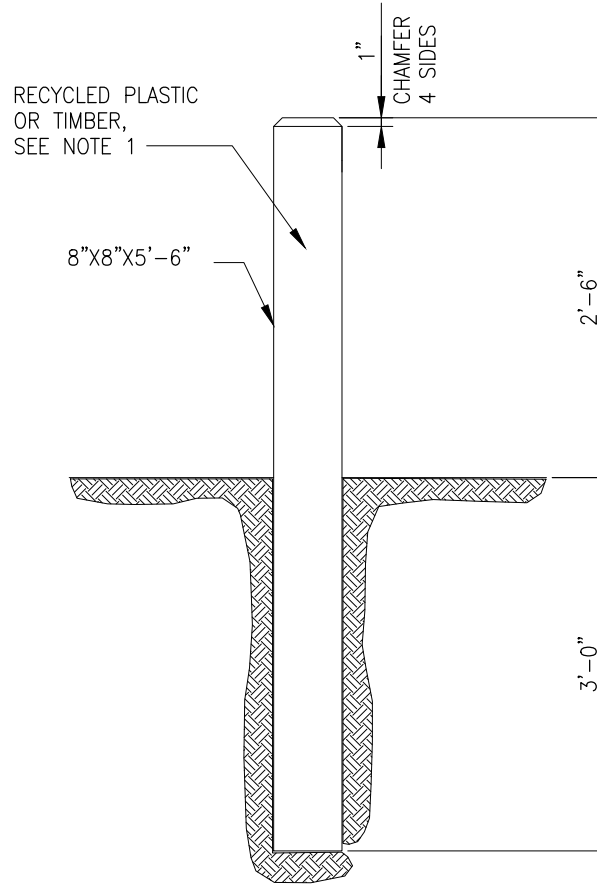

FIXED BOLLARD

NOTES:

1. RECYCLED PLASTIC BOLLARD SHALL BE WHITE. TIMBER SHALL BE DOUGLAS FIR, DENSE CONSTRUCTION GRADE, AND SHALL BE PRESSURE TREATED WITH A WATERBORNE PRESERVATIVE (ACA, CCA, ACZA) IN ACCORDANCE WITH THE REQUIREMENTS OF SEC 9-09.3 (1) OF THE WSDOT/APWA STANDARD SPECIFICATIONS. TOP 5 IN. OF TIMBER SHALL BE PAINTED WHITE.
2. STEEL TUBE SHALL CONFORM TO ASTM A53 GRADE A.
3. NUTS, BOLTS, & WASHERS SHALL CONFORM TO ASTM A307.
4. ALL STEEL PARTS SHALL BE GALVANIZED.
5. CONCRETE SHALL BE CLASS 4000.
6. SEE SEC 5.08.
7. MIN 50 IN. SPACING ON TRAILS LESS THAN 10 FT WIDE. 60 IN. SPACING ON TRAILS 10 FT OR WIDER.

NOT TO SCALE



**CITY OF DES MOINES
PUBLIC WORKS DEPARTMENT**

ENGINEERING SERVICES
21650 11TH AVENUE SOUTH
DES MOINES, IA 50319



BOLLARDS

DM.E3.1

REVISED: 02/23